

# Modern technology in punching machines

## Leader in manufacturing

**GEKA** machines are manufactured in modern facilities assigned exclusively for the production of shearing and punching machines.

The optimization of these production systems together with the performance obtained are to the advantage of the future users of **GEKA** machines and we look forward to counting you among them.

## Leader in conception

**GEKA** hydraulic punching machines have been designed by highly experienced engineers with the support of powerful CAD CAM equipments and have been finished taking into account the suggestions of some of more than 25.000 users of **GEKA** punching and shearing machines. Our most sincere gratitude to all these people who cooperate in the continuous improvement of our quality, making possible that our **GEKA** punching machines, **PUMA**, models can offer the following features:

- Technically dimensioned bed.
- Cylinder with extra guide.
- Head with a strong and accurate system in order to avoid distortions.
- Progressive centering of tool.
- Rapid tool-change.
- Safety guards
- Free room for mounting special equipments.
- Excellent working speed.
- A great variety of standard and special optional equipments for a wide range of applications

---

### **MAQUINARIA GEKA S.A.**

Zerradi Poligonoa, 1- P.O.Box 163 – Telf: +34 943 49 00 34 – Fax: +34 943 49 12 37

e-mail: [geka@geka.es](mailto:geka@geka.es) – <http://www.geka.es> - 20180 OIARTZUN – GIPUZKOA-ESPAÑA



---

**MAQUINARIA GEKA S.A.**

Zerradi Poligonoa, 1- P.O.Box 163 - Telf: +34 943 49 00 34 - Fax: +34 943 49 12 37

e-mail: [geka@geka.es](mailto:geka@geka.es) - <http://www.geka.es> - 20180 OIARTZUN - GIPUZKOA-ESPAÑA

## Leader in service

MAQUINARIA **GEKA** has developed a specific department for designing and producing the special equipments demanded for making different tasks, according to the users requirements.

This professional advice and design service answers for the performance and output of GEKA machines when special applications are required.



---

### MAQUINARIA GEKA S.A.

Zerradi Poligonoa, 1- P.O.Box 163 – Telf: +34 943 49 00 34 – Fax: +34 943 49 12 37

e-mail: [geka@geka.es](mailto:geka@geka.es) – <http://www.geka.es> – 20180 OIARTZUN – GIPUZKOA-ESPAÑA

## Special attachments



1



2



Knowing the universality of **PUMA** punching machines, **GEKA** has a complete range of optional equipment. For further information please ask for the accessories catalogue:

1. Multistop table
2. Punching equipment for larger diameters
3. CNC gauge table Semi Paxy 1000

---

### MAQUINARIA GEKA S.A.

Zerradi Poligonoa, 1- P.O.Box 163 – Telf: +34 943 49 00 34 – Fax: +34 943 49 12 37

e-mail: [geka@geka.es](mailto:geka@geka.es) – <http://www.geka.es> – 20180 OIARTZUN – GIPUZKOA-ESPAÑA



Conscientes de la universalidad de las punzonadoras **PUMA**, **GEKA** dispone de una gama completa de equipos opcionales. Para una mayor información solicite el catálogo de accesorios:

- Mesa multitope
- Equipo de punzonado de diámetros mayores.
- Mesa Semi Paxy 1000 CNC

---

**MAQUINARIA GEKA S.A.**

Zerradi Poligonoa, 1- P.O.Box 163 – Telf: +34 943 49 00 34 – Fax: +34 943 49 12 37

e-mail: [geka@geka.es](mailto:geka@geka.es) – <http://www.geka.es> – 20180 OIARTZUN – GIPUZKOA-ESPAÑA

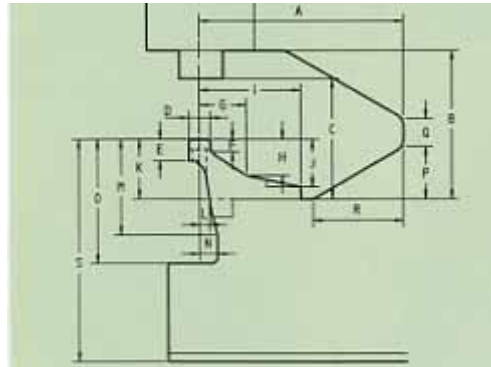

MODELS		A	B	C	D	E	F	G	H	I	J	K	L	M	N	O	P	Q	R	S
<b>PUMA 55</b>	S	500	340	270	65	55	33	120.5	81	233.5	81	137	25	231	45	237	102	78	185	1060
	SD	750	340	270	65	55	33	120.5	81	233.5	81	137	25	231	45	327	102	78	185	810
<b>PUMA 80</b>	S	510	370	300	65	62	31	123	89	253.5	89	144	25	234	45	304	130	70	234	1094
	SD	750	370	300	65	62	31	123	89	253.5	89	144	25	234	45	304	130	70	278	1194
<b>PUMA 110</b>	S	500	420	350	79	79	40	140.5	96	267	96	161	27	326	47	461	95	125	100	991
	SD	750	420	350	79	79	40	140.5	96	267	96	161	27	326	47	461	95	125	100	1066
<b>PUMA 165</b>	S	510	450	380	85	79	35	158	104	430	160	200	25	372	45	450	0	240	0	1060
	SD	760	450	380	85	79	35	158	104	430	160	200	25	372	45	450	141	98	245	1060
<b>PUMA 220</b>	S	510	450	375	85	79	33	162	100	435	151	198	30	-	30	483	0	330	0	1013
	SD	800	450	375	85	79	33	162	100	435	151	198	30	-	30	483	125	200	216	1013

---

### MAQUINARIA GEKA S.A.

Zerradi Poligonoa, 1- P.O.Box 163 – Telf: +34 943 49 00 34 – Fax: +34 943 49 12 37

e-mail: [geka@geka.es](mailto:geka@geka.es) – <http://www.geka.es> – 20180 OIARTZUN – GIPUZKOA-ESPAÑA

## Range of PUMA punching machines

### 5 PUMA models

#### 2 Versions of every model: standard throat and deep throat.

- Machines driven by a vertical travelling cylinder and with special guiding
- Rapid tool change.
- Wide punching table with millimetre stops.



### PUMA 55-500

#### In mm.s

Punching power 550 KN

Max.capacity :  $\varnothing 40 \times 10$  mm.  
 $\square 28 \times 11$  mm.

Throat : 500mm.

#### In inches

Punching power 550 KN

Max.capacity :  $\varnothing 1 \frac{9}{16} \times \frac{3}{8}$ "  
 $\square 1 \frac{1}{8} \times \frac{7}{16}$ "

Throat : 20 "

### MAQUINARIA GEKA S.A.

Zerradi Poligonoa, 1- P.O.Box 163 – Telf: +34 943 49 00 34 – Fax: +34 943 49 12 37

e-mail: [geka@geka.es](mailto:geka@geka.es) – <http://www.geka.es> – 20180 OIARTZUN – GIPUZKOA-ESPAÑA



## PUMA 80/750

### In mm.s

Punching power 800 KN  
Ø40 x 14 mm.  
Max.capacity : Ø24 x 24 mm.  
□ 28 x 16 mm.  
Throat: 750mm.

### In inches

Punching power 800 KN  
Ø1 9/16" x 9/16"  
Max.capacity : Ø 1" x 1"  
□ 1 1/8" x 5/8"  
Throat : 29 1/2 "

---

### MAQUINARIA GEKA S.A.

Zerradi Poligonoa, 1- P.O.Box 163 – Telf: +34 943 49 00 34 – Fax: +34 943 49 12 37

e-mail: [geka@geka.es](mailto:geka@geka.es) – <http://www.geka.es> – 20180 OIARTZUN – GIPUZKOA-ESPAÑA

**PUMA 165/500****In mm.s**

Punching power 1650 KN  
Ø40 x 30 mm.  
Max.capacity : Ø34 x 34 mm.  
□ 28 x 28 mm.  
Throat: 500mm.

**In inches**

Punching power 1650 KN  
Ø1 9/16" x 3/16"  
Max.capacity : Ø 15/16" x 15/16"  
□ 1 1/8" x 1/8"  
Throat : 20 "

**Rational design**

Solid hydraulic equipment fitted with components of the best international brands, and with maintenance and service facilities all over the world.

**MAQUINARIA GEKA S.A.**

Zerradi Poligonoa, 1- P.O.Box 163 – Telf: +34 943 49 00 34 – Fax: +34 943 49 12 37

e-mail: [geka@geka.es](mailto:geka@geka.es) – <http://www.geka.es> – 20180 OIARTZUN – GIPUZKOA-ESPAÑA

## Important points

### PUNCHING

The use of a separate cylinder allows the establishment of an independent work station, offering large die space for the assembly of special tools.

1. PUMA double-acting sectionalized cylinder
2. Cylinder support
3. Stroke adjusting stop
4. Wide stroke for punching, bending, countersinking and forming
5. Ample adjustable guidance to avoid distortion
6. Extra guide to better absorb off-center loads and thus better protect hydraulic seals
7. Cylinder for special tooling fixing
8. Rapid tool-change
9. Adjustable punch stripper
10. Gauging table with millimetre scales
11. Positioning stop up to 500mm
12. Gooseneck die-holder for punching plates and sections
13. Bolts for front-to-back alignment
14. Bolts for left to right alignment
15. Bolt for mounting gooseneck die holder support block

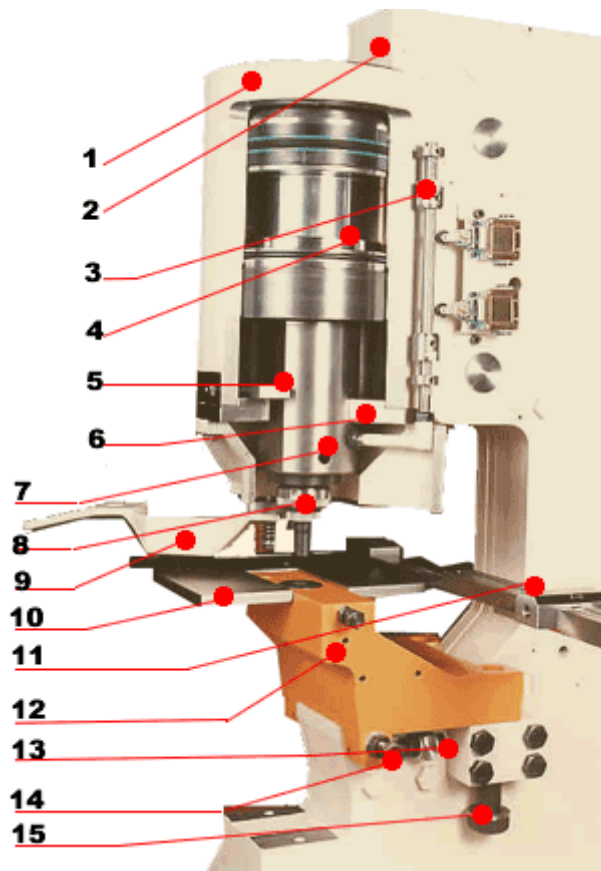

### Post sale service

**GEKA** has a complete network of concessionaries in over 50 countries who will endeavour to find a solution for all your punching problems, the maintenance of all existing equipment, and the supply of all spare parts, original punches and dies, etc. We are sure that their professional advice will be most helpful.

---

#### MAQUINARIA GEKA S.A.

Zerradi Poligonoa, 1- P.O.Box 163 – Telf: +34 943 49 00 34 – Fax: +34 943 49 12 37

e-mail: [geka@geka.es](mailto:geka@geka.es) – <http://www.geka.es> – 20180 OIARTZUN – GIPUZKOA-ESPAÑA

# Hydraulic portable punching machine

MOD."P.P.50"

## CHARACTERISTICS

	In mm.s	In inches
Punching power	500 KN	500 Kn
Maximum capacity (GO)	Ø 27x13mm	Ø 1/16" x 1/2"
(PR)	Ø 40x9mm	Ø 9/16" x 3/8"
Maximum travel	30mm	1 3/16"
Throat	130mm	5 1/8"
Motor power	3KW	3KW
Stroke per minute	23	23
Net weight (GO)	355 Kgs	780 Lbs.
(PR)	415Kgs	910 Lbs.
Brut weight (GO)	480 Kgs	1055 Lbs.
(PR)	540 Kgs	1190 Lbs.
Dimensions with seaworthy packing included	1.1x0.9x155m	43"x35"x61"
Volume	1.53m3	54Ft.
SPECIAL ATTACHMENTS		
Large diameter punching (PR)	Ø 50x7mm	Ø 2" x 9/32"



## MAQUINARIA GEKA S.A.

Zerradi Poligonoa, 1- P.O.Box 163 – Telf: +34 943 49 00 34 – Fax: +34 943 49 12 37

e-mail: [geka@geka.es](mailto:geka@geka.es) – <http://www.geka.es> – 20180 OIARTZUN – GIPUZKOA-ESPAÑA

<b>CHARACTERISTICS OF HIDRAULIC PUNCHING MACHINES in mm.s</b>					
	<b>PUMA-55</b>	<b>PUMA-80</b>	<b>PUMA-110</b>	<b>PUMA-165</b>	<b>PUMA-220</b>
Punching power KN.	550	800	1100	1650	2200
Maximum capacity mm.	Ø40x10	Ø40x14	Ø40x20	Ø40x30	Ø40x40
Throat mm	500 /750	510/750	500/750	510/ 760	510 /800
<b>SECTION PUNCHING WITH GOOSENECK SUPPORT</b>					
I on flange mm.	100-300	100-300	100-450	100-450	100-450
I on web mm.	100-500	100-500	100-500	120-500	120-500
U on flange mm.	100-300	100-300	120-400	120-400	120-400
U on web mm.	120-260	120-380	120-400	120-400	120-400
<b>GENERAL FEATURES</b>					
Motor power KW.	5	9	9	15	20
Strokes per minute with 20mm. Travel	37	40	28	28	25
Maximum travel mm.	60	70	80	100	100
Working height 500/750 mm.	1060/810	1094/1194	991/1066	1060/1060	1013/1013
Net weight 500/750 Kg.	1150/1885	1715/2115	3150/3970	4290/4525	5200/5500
Gross weight 500/750....Kg.	1320/2100	1925/2350	3400/4300	4700/5000	5700/6000
Volume 500/750mm <sup>3</sup>	3,63/4,17	4,53/5,87	5,55/6,82	7,31/8,95	9,63/10
Volume with seaworthy 500m <sup>3</sup> packing 700 m <sup>3</sup>	1,55x1,2x1,95 1,93x1,2x1,8	1,7x1,3x2,05 2,1x1,3x2,15	2,08x1,3x2,05 2,28x1,3x2,3	2,03x1,6x2,25 2,03x1,6x2,35	2,56x1,3x2,35 2,66x1,3x2,35
<b>SPECIAL ATTACHMENT</b>					
Tube notching mm.	60	60	60	60	60
Large diameter punching mm.	Ø100x4	Ø100x6	Ø100x8	Ø100x12	Ø100x16

## MAQUINARIA GEKA S.A.

Zerradi Poligonoa, 1- P.O.Box 163 – Telf: +34 943 49 00 34 – Fax: +34 943 49 12 37

e-mail: [geka@geka.es](mailto:geka@geka.es) – <http://www.geka.es> – 20180 OIARTZUN – GIPUZKOA-ESPAÑA

HYDRAULIC PUNCHING MACHINES IN INCHES					
	55	80	110	165	220
Punching Power KN.	550	800	1100	1650	2200
Maximum capacity	1 9/16" x 3/8"	1 9/16"x9/16"	1 9/16"x3/4"	1 9/16"x3/16"	1 9/16"x1 9/16"
Throat	20"	20"	20"	20"	20"
	30"	30"	30"	30"	30"
<b>SECTION PUNCHING WITH GOOSENECK SUPPORT</b>					
I on flange	7"-12"	7"-11"	9 1/2"-18"	10"-18"	10"-18"
I on web	4"-16"	4"-18"	4"-20"	5"-20"	5"-20"
U on flange	4"-12"	4"-12"	5"-182	5"-18"	5"-18"
U on web	5"-9"	4"-9 1/2"	5"-11"	5"-15"	5"-15"
<b>GENERAL FEATURES</b>					
Motor power KW.	5	9	9	15	20
Strokes per min.with 3/4 "					
mm. Travel	37	40	28	28	25
Maximum travel	2 3/8"	2 3/4"	3 1/8"	4"	4"
Working height 20"/30"	42"/32"	43"/47"	39"/42"	42"/42"	40"/40"
Net Weight 20"/30"					
Pounds	2530/4147	3773/4653	6930/8734	9438/9955	11440/12100
Gross Weight 20"/30"					
Pounds	2904/4620	4235/5170	7480/9460	10340/11000	12540/13200
Volume 20"/30" Ft.	128/147	160/207	196/240	258/316	340/353
Volume with seaworthy packing					
20"	61"x47"x77"	67"x51"x81"	82"x51"x81"	80"x63"x88"	100"x63"x92"
30"	76"x47"x71"	83"x51"x85"	90"x51"x90"	80"x63"x92"	105"x63"x92"
<b>SPECIAL ATTACHMENTS</b>					
Tube notching	2 3/8"	2 3/8"	2 3/8"	2 3/8"	2 3/8"
Larger diameter punching	4" x 5/32"	4" x 1/4"	4" x 5/16"	4" x 1/2"	4" x 5/8"

## MAQUINARIA GEKA S.A.

Zerradi Poligonoa, 1- P.O.Box 163 – Telf: +34 943 49 00 34 – Fax: +34 943 49 12 37

e-mail: [geka@geka.es](mailto:geka@geka.es) – <http://www.geka.es> – 20180 OIARTZUN – GIPUZKOA-ESPAÑA